

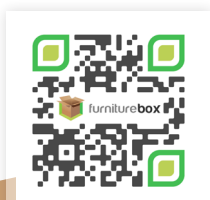

CARSON

ASSEMBLY GUIDE

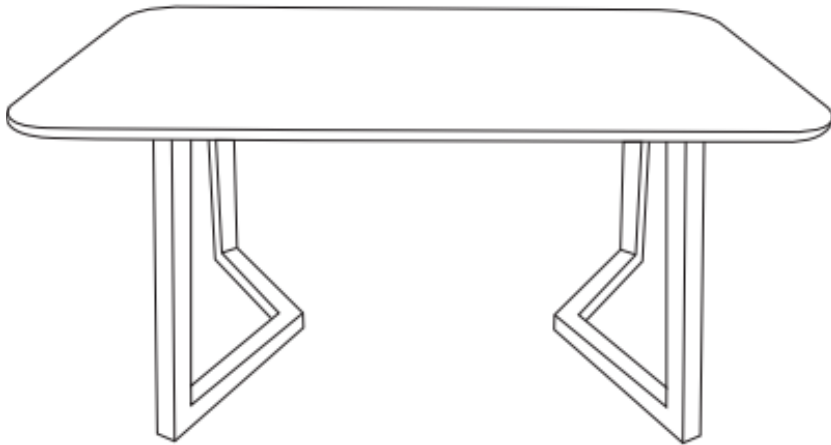

SCAN ME

www.furniturebox.co.uk

Scan QR code for more tips,
advice and assembly video or visit
furniturebox.co.uk/club/carson

Important - Please read these instructions fully before starting assembly



SAFETY AND CARE ADVICE



NO POWER TOOLS

SAFETY AND CARE ADVICE

- Check you have all the components and tools listed.
- Remove all fittings from the plastic bags and separate them into their groups.
- We do not recommend the use of power drills/drivers for inserting screws, as this could damage the unit. Only use hand screwdrivers and Allen keys.
- Keep children and animals away from the work area, small parts could cause choking if swallowed.
- Make sure you have enough space to layout the parts before starting.
- Assemble the item as close to its final position (in the same room) as possible.
- Do not overtighten the nuts to avoid causing damage to the threads.
- Only clean using a damp cloth and mild detergent, do not use bleach or abrasive cleaners.
- From time to time check that there are no loose screws on this unit
- This product should not be discarded with household waste. Take to your local authority waste disposal centre



Follow us on Instagram
@furniturebox_uk

IMPORTANT INFORMATION



30 MINUTE
BUILD









TWO
PERSON



MAXIMUM
CAPACITY 100Kg

PLEASE CHECK CAREFULLY AND MAKE SURE YOU HAVE ALL FITTINGS AND TOOLS LISTED BELOW BEFORE YOU START.

Parts	
①	
Top	x1
②	
Bar (For 160x90cm only)	x2
③	
Leg	x2

Fixings	
A	
Ø8x20mm	x16PCS
B	
Ø8x50mm	x6PCS
C	
8x18mm	x22PCS
D	
5mm	x1PCS

NOTE: The quantities above are the correct amount to complete the assembly. In some cases more fittings may be supplied than are required.

STEP 1

Use a clean, flat, soft surface to avoid any bumps or scratches.

Place your tabletop [1] face-down on the flat surface.

For the 6 Seater option only: you need to attach the 2 support bars [2] to the underside of the table. Use 1x washer [C] followed by 1x bolt [B] for each hole - 3 per bar, 6 in total. Tighten with Allen key [D].

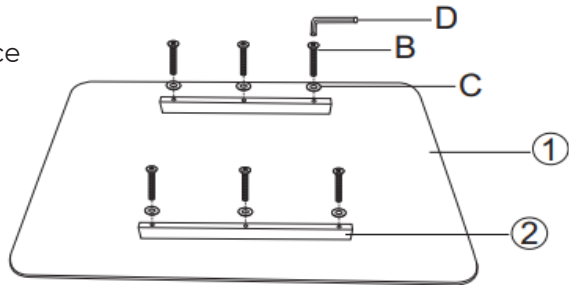

(For Size 160x90cm only)

STEP 2

Connect the 2 legs [3]. Use 1 x washer [C] followed by 1 x bolt [A] for each hole - 8 per leg, 16 in total. Tighten with Allen key [D].

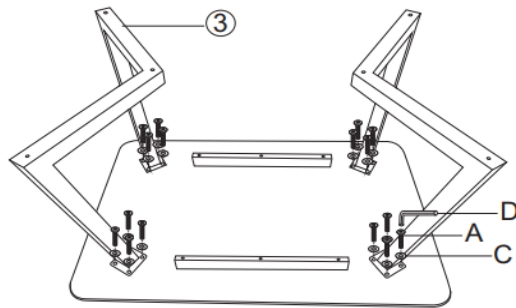

STEP 3

Carefully and with help, flip your table upright onto its legs. Check for stability. Your new table is now ready to use.

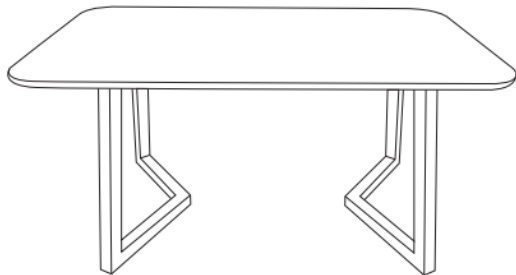

Follow us on Instagram
@furniturebox_uk

LOOKING GOOD!

Now you've assembled your product find out how to care for your item and keep it looking brand new.

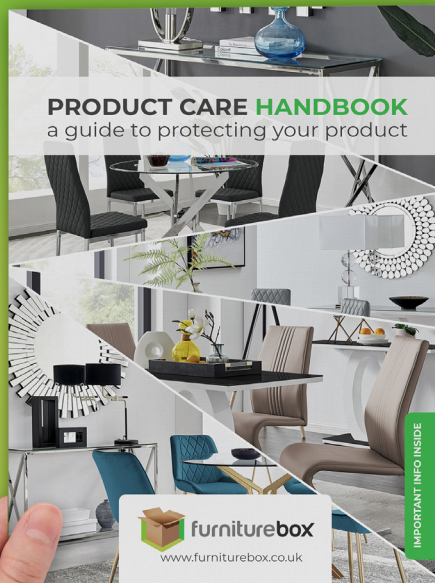

Look for your care guide in the box or visit:
www.furniturebox.co.uk/club/care-guide



OUR 2 YEAR* GUARANTEE

our products come with a 2 year guarantee to give you peace of mind shopping at Furniturebox

*excludes some garden furniture items which have a 1 year guarantee



WHAT THE GUARANTEE COVERS



PRE-INSERTED FIXINGS
e.g. lose metal threads



FAULTY JOINTS
e.g. legs bending



EXTERNAL FIXING FAULTS
e.g. bonding/glue



STRUCTURAL INTEGRITY
e.g. the frame of the product



ACTIVATE YOUR GUARANTEE ONLINE

scan this QR code with your phone to read the full guarantee online and register your product. It only takes a moment to fill out. Or visit: furniturebox.co.uk/our-guarantee

Furniturebox UK, Unit 6, St Modwen's Park,
Chippenham, SN15 5BD
Tel: 01747 863333 Email: sales@furniturebox.co.uk