

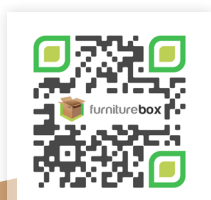

ATTICUS DESK

ASSEMBLY GUIDE

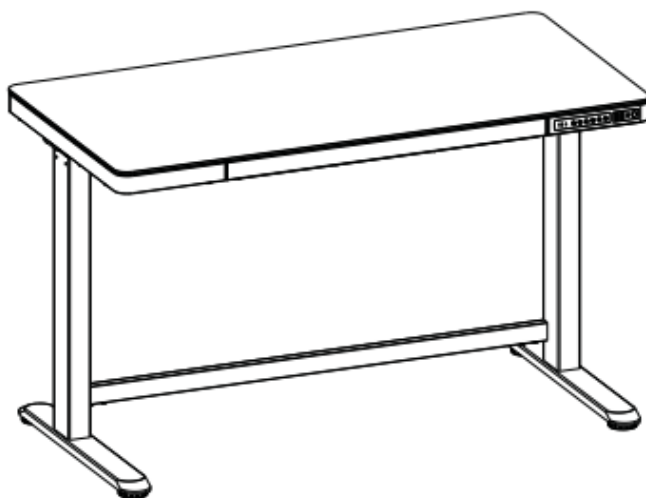

SCAN ME



www.furniturebox.co.uk

Scan QR code for more tips,
advice and assembly video or visit
furniturebox.co.uk/club/atticus

Important - Please read these instructions fully before starting assembly



**SAFETY AND
CARE ADVICE**



NO POWER TOOLS

SAFETY AND CARE ADVICE

- Check you have all the components and tools listed.
- Remove all fittings from the plastic bags and separate them into their groups.
- We do not recommend the use of power drills/drivers for inserting screws, as this could damage the unit. Only use hand screwdrivers and Allen keys.
- Keep children and animals away from the work area, small parts could cause choking if swallowed.
- Make sure you have enough space to layout the parts before starting.
- Assemble the item as close to its final position (in the same room) as possible.
- Do not overtighten the nuts to avoid causing damage to the threads.
- Only clean using a damp cloth and mild detergent, do not use bleach or abrasive cleaners.
- From time to time check that there are no loose screws on this unit
- This product should not be discarded with household waste. Take to your local authority waste disposal centre



Follow us on Instagram
@furniturebox_uk

IMPORTANT INFORMATION



30 MINUTES
BUILD



TWO
PERSON



MAXIMUM
CAPACITY
50Kg

PLEASE CHECK CAREFULLY AND MAKE SURE YOU HAVE ALL FITTINGS AND TOOLS LISTED BELOW BEFORE YOU START.

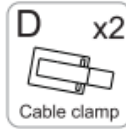
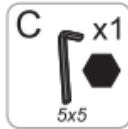

Technical data

Max. Weight Capacity	50KG
Height Range	720-1210mm
Drawer Stroke	230mm
Charging Ports/ Child Lock	

Component list

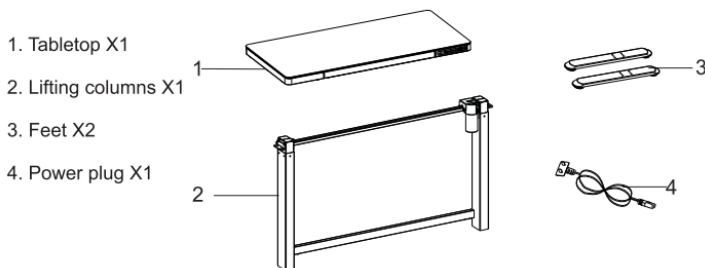

NOTE: The quantities above are the correct amount to complete the assembly. In some cases more fittings may be supplied than are required.

STEP 1

Install the tabletop and the lifting columns

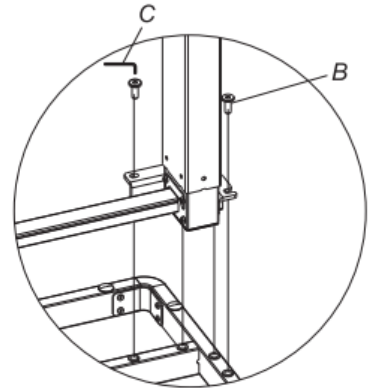
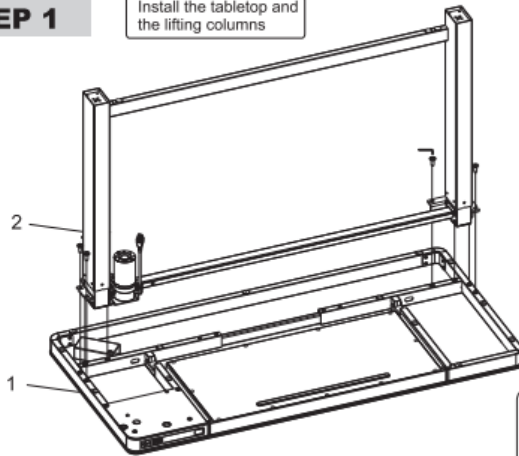

Use a hexagon allen key(C) and M8 screws to assemble the tabletop(1) and lifting columns(2).
 Note: Do not touch the surface directly to the ground during installation to avoid scratching the tabletop by sharp objects.

STEP 2

Install the feet

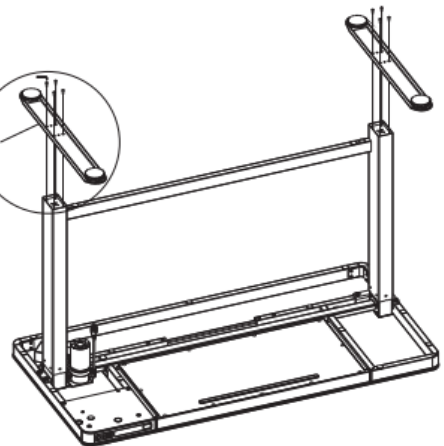
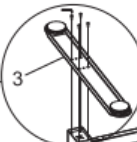
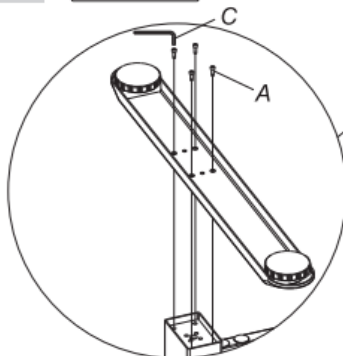

Use a hexagon allen key(C) and M6 screws(Ax8) to install the feet to the lifting columns. Pay attention to the orientation.



Follow us on Instagram
 @furniturebox_uk

STEP 3

Install the motor and power lines

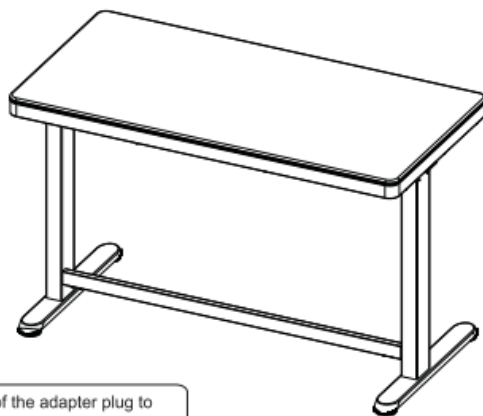
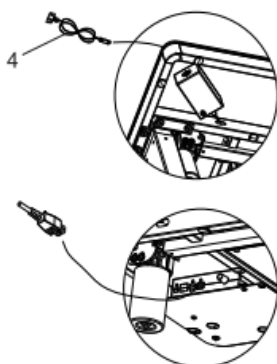

Connect the motor plug to the control box, then connect one side of the adapter plug to the adapter, another side to the power line.
Note: the motor and power lines can be fixed by cable clamp according to actual use.



Operation Instruction

Key button

LED Screen

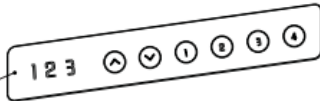

1. Touch the up/down button to adjust the height of the desk; the desktop runs to the lowest point and displays bot; the desktop runs to the highest point, displays top.
2. key button: 1,2,3,4 are the four height memory keys.
 - (1). When the desk is in a static state, long press the button "1" for three seconds, the display shows "5-1", which means the save is successful.
 - (2). Buttons "2", "3", and "4" all have the same height memory function as button "1", repeat the above steps to save the height to the corresponding position 2 or 3 or 4, and the display screen will corresponding show "5-2" or "5-3" or "5-4".
 - (3). When the tabletop is at any height, press the "1" or "2" or "3" or "4" button to automatically adjust to the previously saved location.
3. Press the 3 and the 4 buttons simultaneously, long press for 5 seconds, the screen will show RST direction, keep pressing to achieve the reset.
4. The desk has two USB ports and one type-C port, they can supply power to other electronics and support charging protocol.
Type-C Output: 5V3A/9V2A/12V1.5A; Type-A Output: 3.6-6.5V2.4A/6.5-9V2A/12V1.5A; Total output power of single port: 18W Max.
When the desk is lifting, the output will be stopped; when lifting stops, the output will be restarted.
5. Short press the "LOCK" button to achieve the child lock function, so as to avoid accidentally touch and guarantee the safety of children; The key lock and unlock is switchable, screen will show "Loc" when the desk is locked.
6. Sensitivity switch, long press the up and down button simultaneously, the anti-collision function will be closed when the screen shows "A-0"; the sensitivity is at 1 level when the screen shows "A-1", the sensitivity is at 2 level when the screen shows "A-2", the sensitivity is at 3 level when the screen shows "A-3", the 3 level is the most sensitive.

● Troubleshooting:

- a. Reset: When the LED shows "E5f", press "▼" button until the desk reaches its lowest height and rebounds to stop, it means the reset has been finished.
- b. When it doesn't work and the LED shows "E01" or "E02", please retry 18 minutes later.
- c. If the "▼" button doesn't work, please check the cable connection and then cut off the power for at least 10 seconds. Reconnect to the power and press "▼" button to start the reset process when it shows the "E5f".
- d. If all these above process are inefficient, please contact our customer service.



Follow us on Instagram
@furniturebox_uk

Common fault treatment

The following tips will help you detected and eliminate the common fault and error. If the fault you met is not listed below, please contact with your supplier. Only the manufacturer and professionals are capable for investigating and correcting those fault and error.

Fault phenomenon	Method
No response while long pressing down arrow after connected with a power supply	1.Check if all the cables be connected well
	2.Contact your supplier or dealer
No response while pressing up arrow/ down arrow after connected with a power supply	1.Check if all the cables be connected well
	2.Contact your supplier or dealer
Rising in a low speed	1. Check if overloaded, max loading: 50kg:
	2. Contact your supplier or dealer
The motor not move as instructed	1. Contact your supplier or dealer
Go down but not go up	1.Reposition
	2.Contact your supplier or dealer
Downward sliding	1. Check if overloaded, max loading: 50kg:
	2. Contact your supplier or dealer
Frequently Reposition	1. Check if overloaded, max loading: 50kg:
	2. Contact your supplier or dealer
Overwork (Duty cycle: Max 2min on/18min OFF)	1. Restart after suspend for 18mins while connecting with power;
	2. Contact your supplier or dealer;
Not enough up&down height	1. Press "3"and "4" together for 3 seconds or more, after hearing continuous beeping for twice, it will restore factory settings
	2.Contact your supplier or dealer



furniturebox



Attention

1. Power supply: AC100V-240V,50/60Hz
2. Service Environment: 0-40°C
3. Unplug the power plug before cleaning, wipe the dust on surface with slight wet dishcloth when cleaning, be careful not to let the drops into the internal parts, not loose the connector.
4. The electric box contains electronic components, metals, plastics, wires etc., so dispose of it in accordance with each country's environmental legislation, not the general household waste.
5. Check carefully to ensure correct and complete assembly before using.
6. Be familiar with all functions and program settings of the product before first use.
7. Children are forbidden to play on the product because of unforeseen action when playing, so any dangerous consequences caused by this improper action will not be on manufacturers.
8. Slight noise caused by the V-ribbed belt or brake system due to structure will not have any effect on the use of the equipment.
9. Corrosive or abrasive materials are forbidden to clean the equipment. Must ensure that the cleaner used will not pollute the environment.
10. This appliance can be used by children aged from 8 years and above and persons with reduced physical, sensory or mental capabilities or lack of experience and knowledge if they have been given supervision or instruction concerning use of the appliance in a safe way and understand the hazards involved. Children shall not play with the appliance.
11. Cleaning and user maintenance shall not be made by children without supervision.
12. If the supply cord is damaged, it must be replaced by the manufacturer, its service agent or a similarly qualified person in order to avoid a hazard.
13. Please make sure there is no hazard sources in your operating environment, e.g., do not litter the tools around. Always be careful to treat the packaging materials in order to avoid any possible danger, e.g. plastic bag may lead to choking hazard to children.
14. Keep the original package of the equipment if necessary in case of the future use in transportation.

Waste disposal



This marking indicates that this product should not be disposed with other household wastes. To prevent possible harm to the environment or human health from uncontrolled waste disposal, recycle it responsibly to promote the sustainable reuse of material resources. To return your used device, please use the return and collection systems or contact the retailer where the product was purchased. They can take this product for environmental safe recycling.



Follow us on Instagram
@furniturebox_uk

LOOKING GOOD!

Now you've assembled your product find out how to care for your item and keep it looking brand new.



Look for your care guide in the box or visit:
www.furniturebox.co.uk/club/care-guide



OUR 2 YEAR* GUARANTEE

our products come with a 2 year guarantee to give you peace of mind shopping at Furniturebox

*excludes some garden furniture items which have a 1 year guarantee



WHAT THE GUARANTEE COVERS



PRE-INSERTED FIXINGS
e.g. lose metal threads



FAULTY JOINTS
e.g. legs bending



EXTERNAL FIXING FAULTS
e.g. bonding/glue



STRUCTURAL INTEGRITY
e.g. the frame of the product



ACTIVATE YOUR GUARANTEE ONLINE

scan this QR code with your phone to read the full guarantee online and register your product. It only takes a moment to fill out. Or visit: furniturebox.co.uk/our-guarantee

Furniturebox UK, Unit 6, St Modwen's Park,
Chippenham, SN15 5BD
Tel: 01747 863333 Email: sales@furniturebox.co.uk